

The Codex

By

Altair Ibn-La'Ahad

I have spent days with the artifact now. Or has it been weeks? Months? I can no longer be certain...

The others come from time to time – offering food or distraction. They say I should separate myself from these studies... Malik has even suggested I abandon them entirely. But I am not yet ready to turn away. This Apple of Eden will be understood. It must be...

Is it a weapon? Is it a catalogue? Is it somehow both? "He who increaseth knowledge, increaseth sorrow..." The philosophy of such a statement I can understand... But for it to be truth – literally true? A society that waged wars with ideas and information in place of steel and swords...

Its function is simple. Elementary, even. Dominion. Control. But the process... the methods and means it employs... THESE are fascinating. Those subjected to its glow are promised all that they desire. It asks only one thing in return: complete and total obedience. And who can truly refuse? It is temptation incarnate.

I remember my own moment of weakness when confronted by Al Mualim, my confidence shaken by his words. He, who had been like a father, was now revealed to be my greatest enemy. Just the briefest flicker of doubt was all he needed to creep into my mind. But I vanquished his phantoms – restored my self-confidence – and sent him from this world. I freed myself. But now I wonder... Did I really? For here I sit – desperate to understand that which I swore to destroy.

This is why: The Apple has a tale to tell. I sense the flickers of something – great and dangerous... We are all at risk. It is my duty to do something about it. I must not – cannot – turn away until I've found the truth.

شيخ الأزهر الحرب

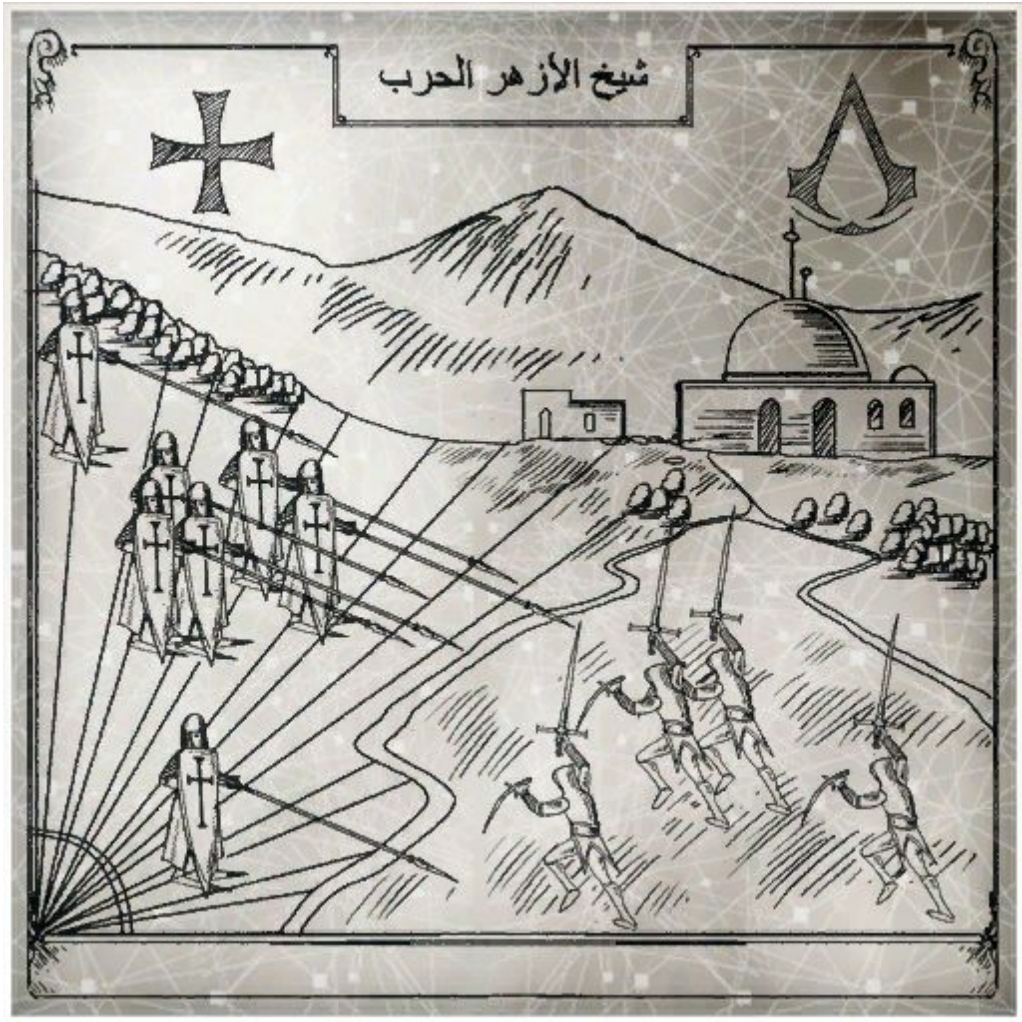

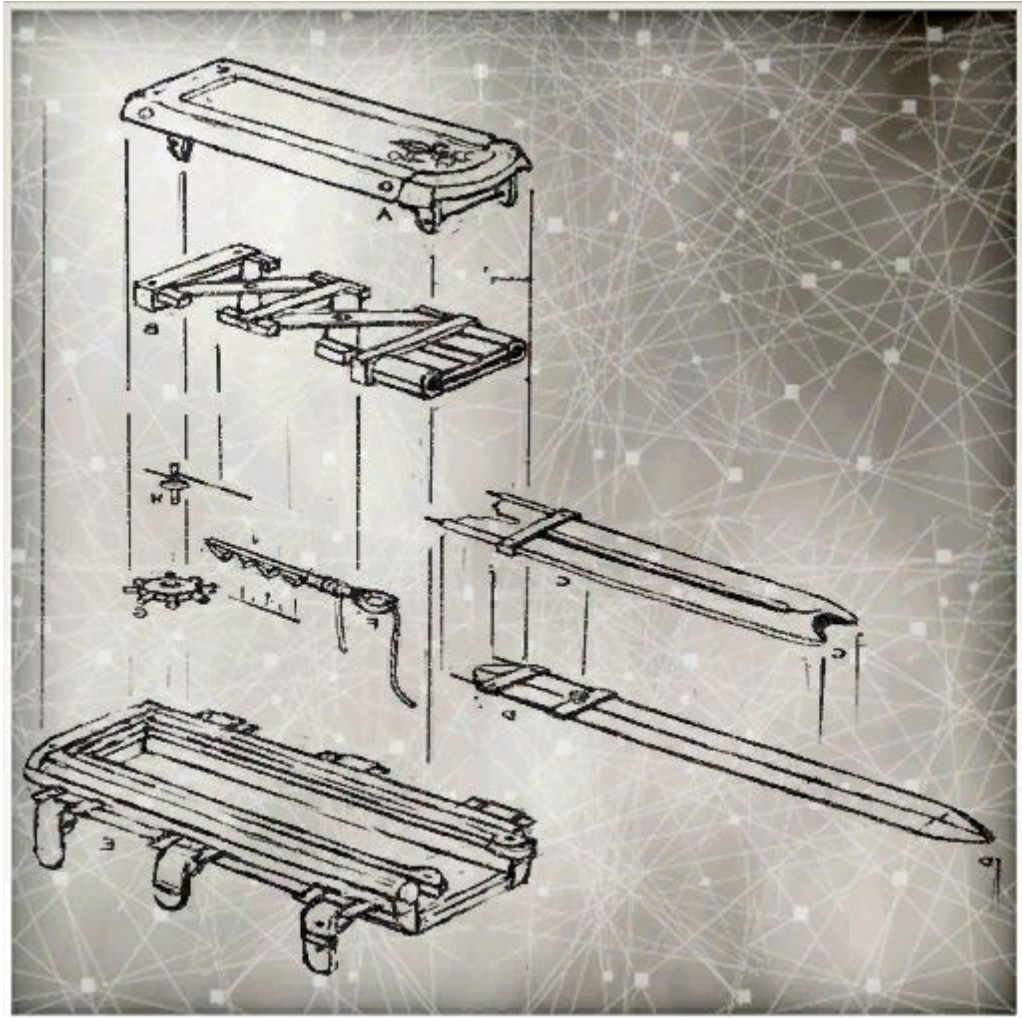

What follows are the three great ironies of the Assassin Order: (1) Here we seek to promote peace, but murder is our means. (2) Here we seek to open the minds of men, but require obedience to a master and set of rules. (3) Here we seek to reveal the danger of blind faith, yet we are practitioners ourselves.

I have no satisfactory answer to these charges, only possibilities... Do we bend the rules in service to a greater good? And if we do, what does it say of us? That we are liars? That we are frauds? That we are weak? Every moment is spent wrestling with these contradictions and in spite of all the years I've had to reflect, still I can find no suitable answer... And I fear that one may not exist.

Nothing is true. Everything is permitted. Does our creed provide the answer, then? That one may be two things – opposite in every way – simultaneously? And why not? Am I not proof? We of noble intentions, possessed of barbaric means? We who celebrate the sanctity of life and then promptly take it from those we deem our enemies?

Who were The Ones That Came Before? What brought them here? How long ago? Centuries? Millenia? Longer still?

So little remains of them...

What drove them out? What of these artifacts?

Messages in a bottle?

Tools left behind to aid and guide us?

Or do we fight for control over their refuse, giving divine purpose and meaning to little more than discarded toys?

Robert de Sable may be dead, but his brotherhood survives. Though less conspicuous in appearance, I fear they remain a threat. Where once they proudly walked the streets – making for easier targets – now they retreat into the shadows. It grows difficult to track them. What wicked things will they weave in the darkness? Our work will be all the more complicated for it. Already there are rumors of a movement on Cyprus. I will have to investigate...

It's made me realize that our tactics, too, must change. It means an end to our fortresses. To our penchant for spectacular displays of public assassinations. We must weave our webs quietly. And we must do so differently than we have in the past.

Though I ask my brothers now to abandon their rituals, I do not ask that they abandon the creed. THIS is what makes us Assassins. Not the removal of a finger. Not a false promise of paradise. Not the prohibition of poison. Our duty is to the people, not to custom. If we must sneak, we shall sneak. If we must use poison, we shall use poison. If our blades can be used without removing fingers, we shall not demand they be taken. And we shall not manipulate our initiates with lies and parlor tricks. We shall speak plainly and honestly. We shall be made anew...

I had thought Adha would be the one to lead me to rest, that I might lay down my blade and live as a normal man. But now I know such dreams are best left to sleep...

Her face. I try to banish it from my mind as I remember the days and nights during which I chased her Templar captors across the sea. I almost got to them in time. Almost. If I had only been faster. Instead, I held her lifeless body in my arms – saw the terror reflected in her fixed, unblinking eyes...

I hunted each man – one by one – until all responsible were gone from the world. But there was no joy in this. No satisfaction or release. Their deaths did not bring her back. Did not heal my wounds. After that, I was certain I would never again feel for a woman as I had for her.

I am fortunate to have been wrong.

Why do our instincts insist on violence?

I have studied the interactions between different species. The innate desire to survive seems to demand the death of the other. Why can they not stand hand in hand? So many believe the world was created by the hand of a divine power – but I see only the designs of a madman, bent on celebrating destruction and desperation.

Our origins seem chaotic. Unintended. Purpose and being instilled solely by the passage of time. Imposed first by nature – and later men...

Over time, any sentence uttered long and loud enough becomes fixed. Becomes a truth. Provided, of course, you can outlast the dissent and silence your opponents. But should you succeed – and remove all challengers – then what remains is, by default, now true.

Is it truth in some objective sense? No. But how does one ever achieve an objective point of view? The answer is you don't. It is literally, physically impossible. There are too many variables. Too many fields and formulae to consider. We can try, of course. We can inch closer and closer to a revelation. But we'll never reach it. Not ever...

And so I have realized, that so long as The Templars exist, they will attempt to bend reality to their will. They recognize there is no such thing as an absolute truth – or if there is – we are hopelessly under-equipped to recognize it. And so in its place, they seek to create their own explanation. It is the guiding principle of their so-named "New World Order"; To reshape existence in their own image. It is not about artifacts. Not about men. These are merely tools. It's about concepts. Clever of them. For how does one wage war against a concept?

It is the perfect weapon. It lacks a physical form yet can alter the world around us in numerous, often violent ways. You cannot kill a creed. Even if you kill all of its adherents, destroy all of its writings – these are a reprieve at best. Some one, some day, will rediscover it. Reinvent it. I believe that even we, the Assassins, have simply re-discovered an Order that predates the Old Man himself...

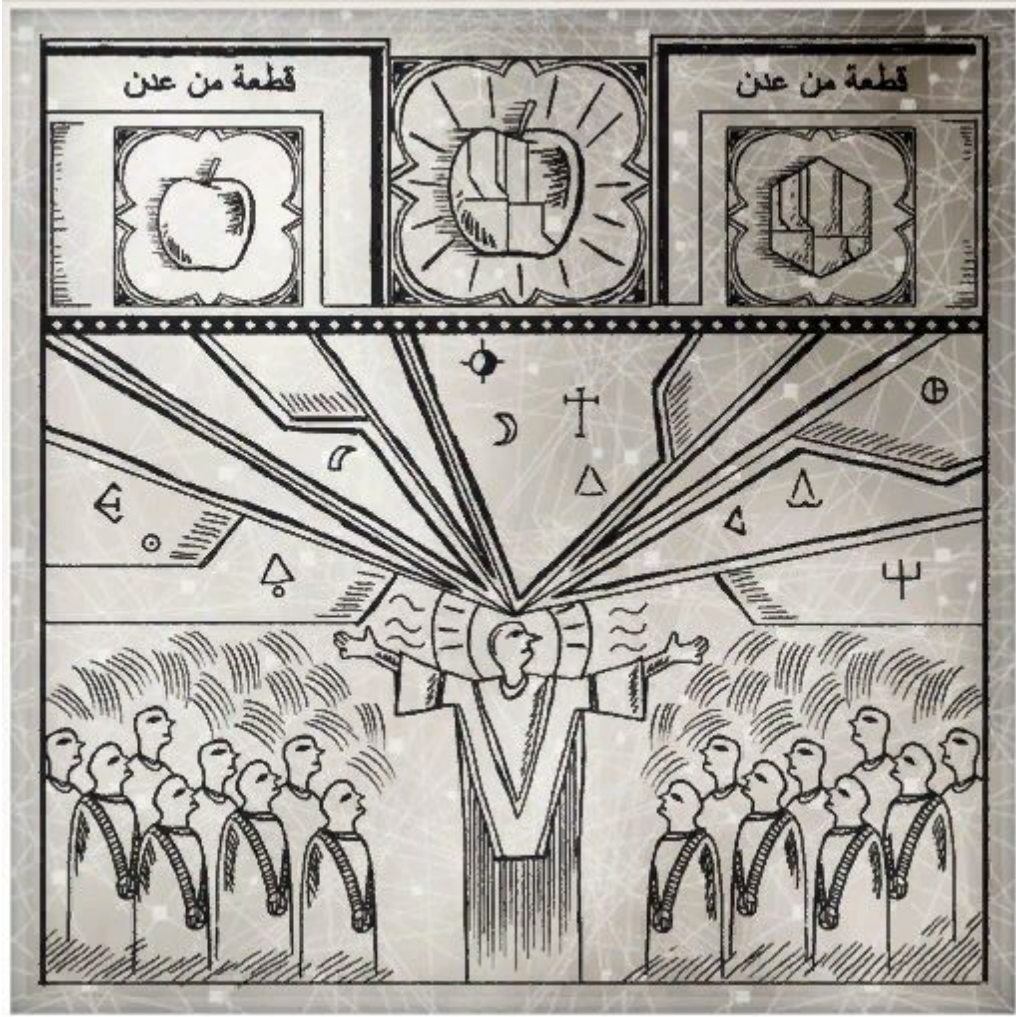

Attis. Dionysus. Horus. Krishna. Mithra. Jesus. Similar stories color their lives. Too similar, I think. Divine birthright. Persecution. Disciples. Miraculous acts. Resurrection...

How is it possible?

Perhaps it isn't... Merely a single story told over the ages? Borrowed then changed to fit the times? Evolving as our tools and language do? Is this tale born of fact or fiction? A bit of both? Could these figures be the same person – their life extended and transformed by a Piece of Eden?

Al Mualim spoke of Jesus as a real person – a mortal who had mastered the arts of manipulation. But what if he was wrong? If these men are real – and if they have walked amongst us many times before – does it mean they'll come again? Perhaps they are here now? So many questions, and every day, even more...

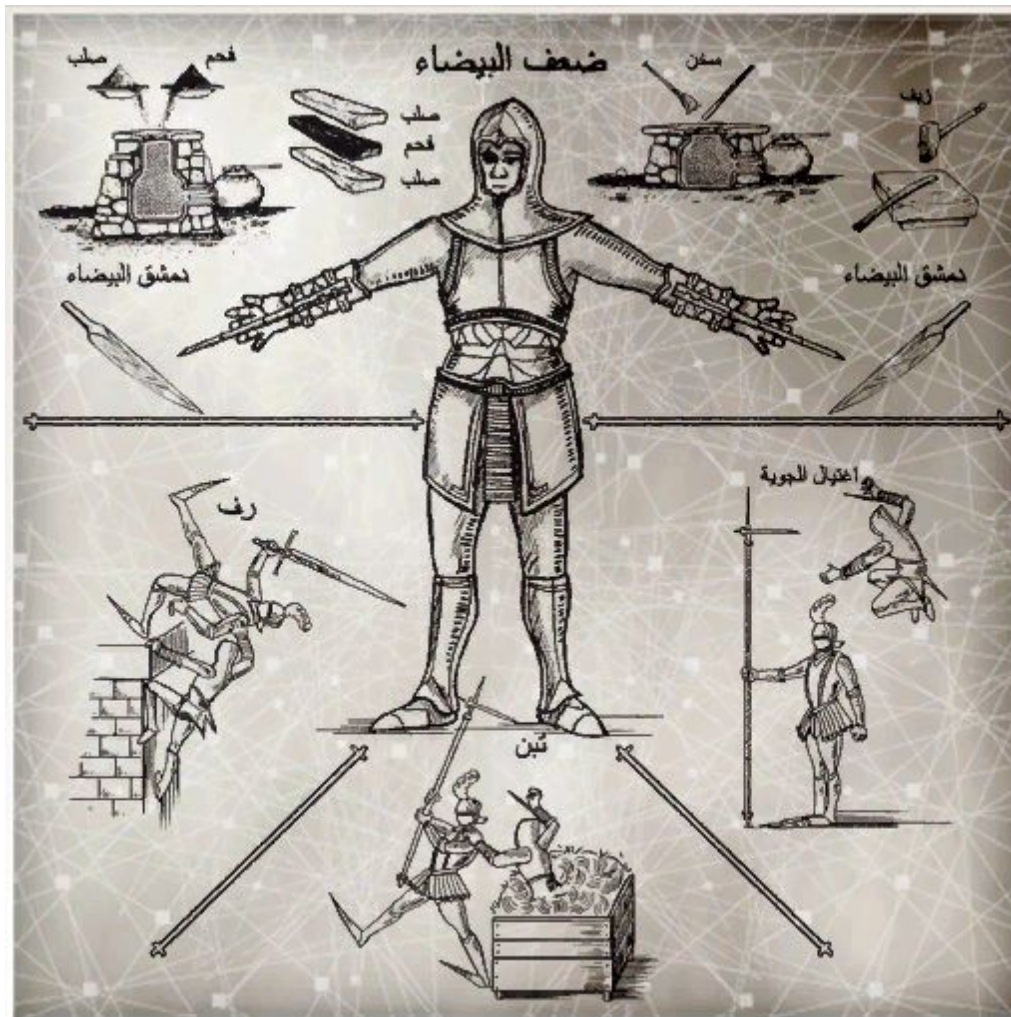

The Hidden Blade has been a constant companion of ours over the years. Some would say it defines us – and they would not be entirely wrong. Many of our successes would not have been possible without it. Still, the device has begun to show it's age – and so I have been researching improvements beyond ending the need to remove one's finger to wield it. The first is the addition of a metal plate that can be used to deflect incoming blows. The other Assassins believe it is forged of a new metal – and credit me with the discovery of the formula (included on this page). It is better that they not know the truth.

I have also worked with Malik to describe new methods of assassination: from on high, from ledges, and from hiding places. Basic movements, but critical nonetheless.

The third and final improvement is the most simple – the provision of a second blade – identical in every way to the first. Should an Assassin ever find himself tasked with dispatching two targets, he need only time his strike in such a way that he might reach both at the same time. These blades will be limited in number since the metals with which we forge them remain difficult to obtain. I will need to think carefully about who shall be allowed to carry two...

Man seeks dominion over all that he encounters. I suppose it is a natural tendency for us to aspire towards mastery of our surroundings. But this should not include other human beings. Every day more and more are pressed into service – by deception or by force. Others, though not so firmly imprisoned, are made to feel as if their lives are worthless. I have seen the ways in which men persecute women. Heard the cruel words hurled at those who come here from other lands. Watched as those who believe or act differently are made to suffer...

We discuss such things often – watching as we do from the spires of Masyaf. What can be done to stop this? To encourage tolerance and equality? Some days we speak of education, believing that knowledge will free us from immorality. But as I walk the streets and see slaves sent off to auction – my heart grows cold. When I see the husband hurl abuses and stones at his wife, insisting she exists only to serve him – my fists clench. And when I see children torn from their parents so that another man might profit – sent off to suffer beneath the desert sun and die...

...On these days, I do not think that dialogue will make a difference.
On these days, I can think only of how the perpetrators need to die.



The Apple is more than a catalog of that which precedes us. Within its twisting, sparking innards I've caught glimpses of what will be. Such a thing should not be possible. Perhaps it isn't. Maybe it is simply a suggestion. How to know? How to be sure?

I contemplate the consequences of these visions: are they images of things to come – or simply the potential for what might be? Can we influence the outcome? Dare we try? And in so doing, do we merely ensure that which we've seen?

I am torn – as always – between action and inaction – unclear as to which – if either – will make a difference. Am I even meant to make a difference? Still, I keep this journal. Is that not an attempt to change – or perhaps guarantee – what I have seen?

Of all the things I've seen, none troubles me more than the image of the flames... Pillars so tall they seemed to pierce the heavens. The ground rumbled and shuddered. Mountains split and crack. Great metal towers splintered, their innards strewn about the ground... And everywhere there was screaming. A chorus so terrible that even now I feel its echoes still.

What is this madness I have seen? Is it them, I wonder? Those who came before... Is this where they went? Into the fire? Into the dust? Perhaps this destructive power is what the Templars seek. That they might hold it over us a command devotion. What hope would we have, then, if they held such darkness in their hands – that they could murder the world...

We are obligated to hide. To be silent. To shape the course of history in secret. But some of my brothers and sisters disagree. They grow angry, insisting it is a mistake to shroud ourselves. They say it slows our work.

But they do not understand the risks. To expose ourselves now would be too dangerous. I fear we would be branded madmen and attacked. So it goes. So it always has. If there is one thing I know for certain, it is that men do not learn by being told. Instead they must be shown.

They must make the connections themselves. If I say unto a man, be kind, be tolerant, be of an open mind – these words will wither and die long before they've affected change.

It would be a waste. And so we must maintain our course...



Legends speaks of a Golden Fleece. Could the two be related?

...I have further refined the metallurgic process, allowing for the production of a suit of armor the likes of which the world has never seen...

...It is possessed of great strength, yet so light as to allow complete freedom...

...I alternate between wonder and fear. Here we have crafted something that will surely change the face of warfare, making those who wear it nigh invincible...

Perhaps it was a mistake to create these pieces. I think it best to erase the formulae. What if it were to fall in the hands of our enemies?

The risk is too great...

I have studied the ancient pagan faiths that came before this more recent obsession with a single, divine creator. They seem to have focused more on the fundamental forces at play in the world around us and less on arbitrary moral rules...

The sun rises in the morning and sets in the evening. The tides ebb and flow. Grass grows, withers, dies, and then in time, emerges from the ground once more. The air turns warm then cools and back again. Some hidden energy keeps us fitted to the ground and pulls us back when we attempt to leave it.

Each of these movements was represented before by a god or goddess. Each force given face, but recognized as something distinct and powerful. Which is not to say there were not connections between these forces – a pantheon of individual spirits – of rules. Invisible hands guiding the progress of the world around us.

And so here there was an attempt to categorize, study, explain, and understand the way things work – even if it was flawed. But no more. Now we are asked to succumb to a far more simplified explanation. How naive to believe there might be a single answer to every question. Every mystery. That there exists a lone divine light which rules over all. They say it is a light that brings truth and love. I say it is a light that blinds us – and forces us to stumble about in ignorance.

I long for the day when men turn away from invisible monsters and once more embrace a more rational view of the world. But these new religions are so convenient – and promise such terrible punishment should one reject them – I worry that fear shall keep us stuck to what is surely the greatest lie ever told.

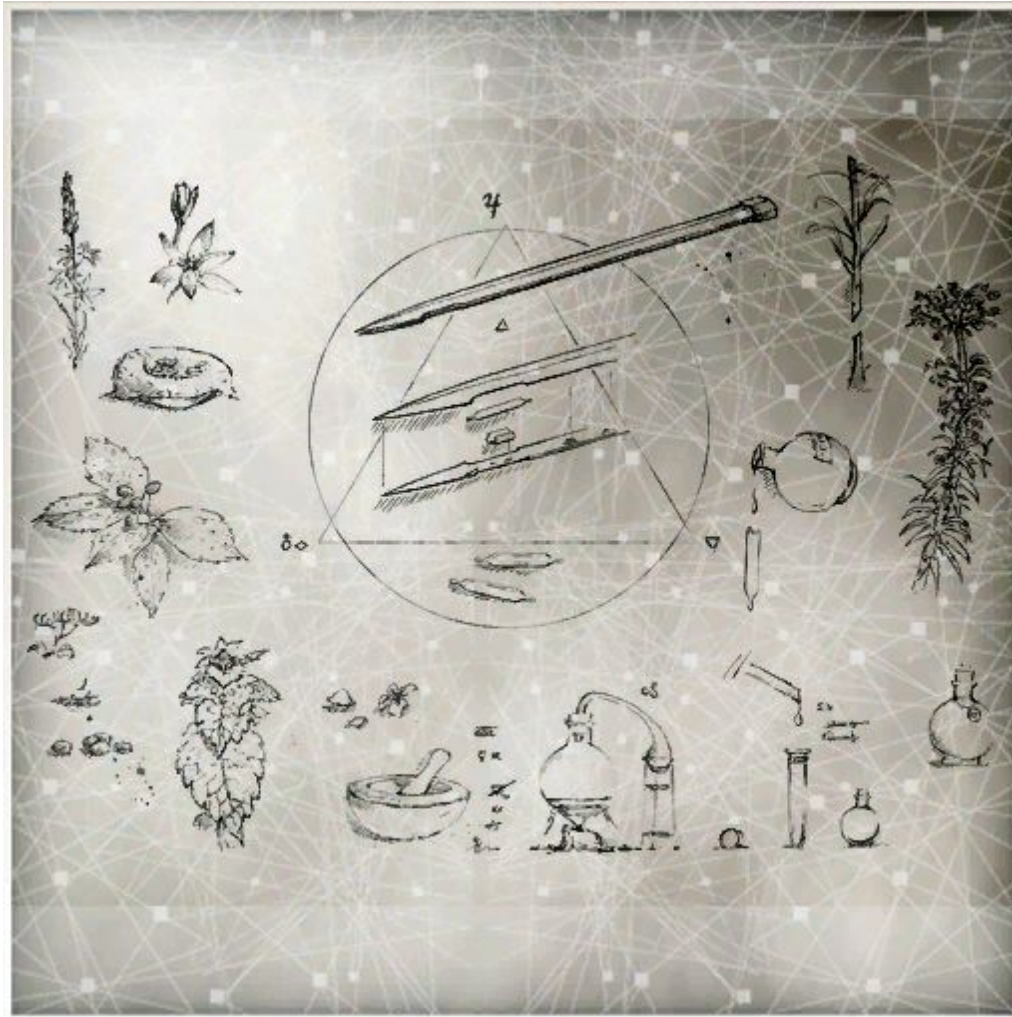

One may cultivate extracts from various plants found throughout the region. More exotic species can sometimes be obtained from traders and travelers, but their properties are less documented and require further examination.

Traditional alchemical implements can be used to distill the poison. Care should be used as certain poisons can be absorbed through exposed skin. Many are those who have lost their lives to carelessness.

One's blade should be hollowed according to the specifications listed herein. Deviation may create fractures within the metal, causing the blade to weaken and possibly break.



What to make of this map? It appears to contain the entire world. Not flat as they claim, either, but round – like a ball. Like the Apple. But how is such a thing even possible? Stranger still are the lands it shows – great patches of the unknown. The unexplored. SO many places yet to be discovered... Are there men there? Are they like us? And if not – different how?

I should like to know the answers. Perhaps – in time – I'll have the chance to travel. To chart a course and make my way to these distant lands...

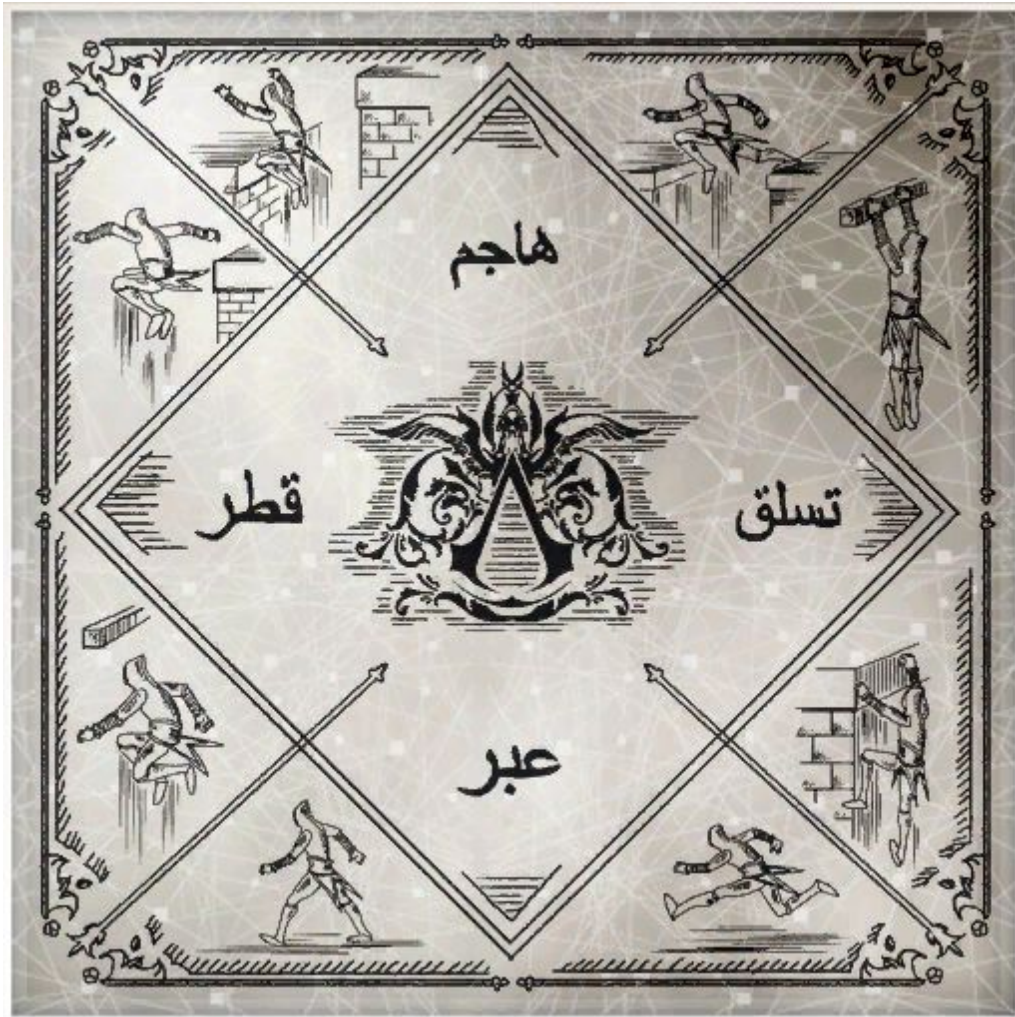

Some days I miss my family... or at least the thought of them. I never knew my parents well, despite them both having lived within these walls. It was our way. Perhaps they were sad, though they showed no sign – it was not allowed.

For my part, so much of my youth was spent in training, there was little time left to reflect upon the separation. And so when they were finally lost to me, it seemed no different than the passing of two strangers. Al Mualim had been as my father, and his was a weak and dishonest love, though at the time it seem enough – better, even. Or so I thought.

Someday I will have a child – such is the way of our Order. And I will not make the same mistake. Nor any who call themselves an Assassin. We shall be allowed to love our children – and, in turn, to be loved. Al Mualim believed such attachments would weaken us – cause us to falter when our lives were on the line. But if we truly fight for what is just, does love not make such sacrifice simpler – knowing that we do so for their gain?



I have the answer now. I know the truth. I shall not touch that wretched thing again. Best that no one do, now or ever. I have tried - at last – to destroy it, but it will neither bend nor break nor melt. Oh the irony – I am certain if I asked, the Apple would tell me what need be done. But even this promise is insufficient. Always it holds one more gift to give. I must refrain. So it shall be sealed. We will take it to the island - once theirs, now ours. There is a treasury there – hidden well - and it shall have to suffice. Risky to separate myself from the artifact that others may discover it. Riskier still to keep it close. In time I will be tempted. I am weak. We all are. Who wouldn't be?

Oh, the things I have seen... The tale is here – inside the text. Not between the lines but beneath them. Where only our eyes might peer. Go and see it for yourself. That you might succeed where I and the others have failed. Time marches on – bringing with it new discoveries and developments. And so at least one day the doorway might be opened and the message delivered.

They will have their prophet.

We are growing larger.

More make their way to our fortresses every day. Men and women. Young and old. From different lands. Of different faiths. Each tells a similar story – of having discovered the first part of our creed: that nothing is true.

Too often, though, the revelation undoes them. They lose their morality, certainty, security. Many are driven mad. We must guide them. Help them to heal. Their minds must not be filled with more fairy tales, but with knowledge instead. Let them have answers – and let those answers be difficult and complex. Such is life.



Success!

We have found a way to alter the structure of the Hidden Blade so that it can be used to launch small projectiles. It is capable of grievous damage – even from great distance. I confess, the means by which I came about the discovery was... risky to say the least. But I have found that in small doses, and with a focused mind, the Apple can be used without ill effect. Or so I hope.

The knowledge of projectile combat is not new to us, having been observed amongst our Eastern neighbors. But their weapons were much larger – and insufficient for our needs. I have now found a way to miniaturize their designs, embedding their fiery weapon into a form that can be worn on the wrist.

We have also refined the formula for combustible powder, such that common ingredients might be used. This is a dangerous bit of knowledge and it is best shared with only our closest allies...

A dark tide rises to the east - an army of such size and power that all the land is made quick to worry. Their leader is a man named Temujin, who has adopted the title Genghis Khan. He sweeps across the lands, conquering and subsuming all who stand in his way.

Whatever his motives, he must be stopped. Were I younger, I might attempt to undertake this work in secret – as I suspect the presence of a Piece of Eden.

But those days are years gone, now. The mantle must be passed. It is time she and I spoke with our sons. We will travel there together, that they may be tested and that this threat might be stopped.

Soon I shall pass from this world. It is my time. All the hours of the day are now colored by the thoughts and fears borne of this realization. I know that the elements of my body will return to the Earth. But what of my consciousness? My identity? That is to say – what of ME?

I suspect it will end. That there is no next world. Nor a return to this one. It will simply be done. Forever.

Our lives are so brief and unimportant. The cosmos cares nothing for us. For what we've done; Had we wrought evil instead of good. Had I chosen to abuse the Apple instead of seal it away. None of it would have mattered.

There is no counting. No reckoning. No final judgement. There is simply silence. And darkness. Utter and absolute... And so I have begun to wonder – might there not be a way to stop – or at least delay – death's embrace?

Surely the ones who came before were not so frail and feeble as we. But I have sworn to be done with the artifact. To not gaze into its core. Still: faced as I am with the prospect of my end, what harm is there in one last look...